

OVERALL WIDTH 1640mm
WEIGHT EMPTY 300kg

COMPRESSOR RATING P6 P9
60W 100W

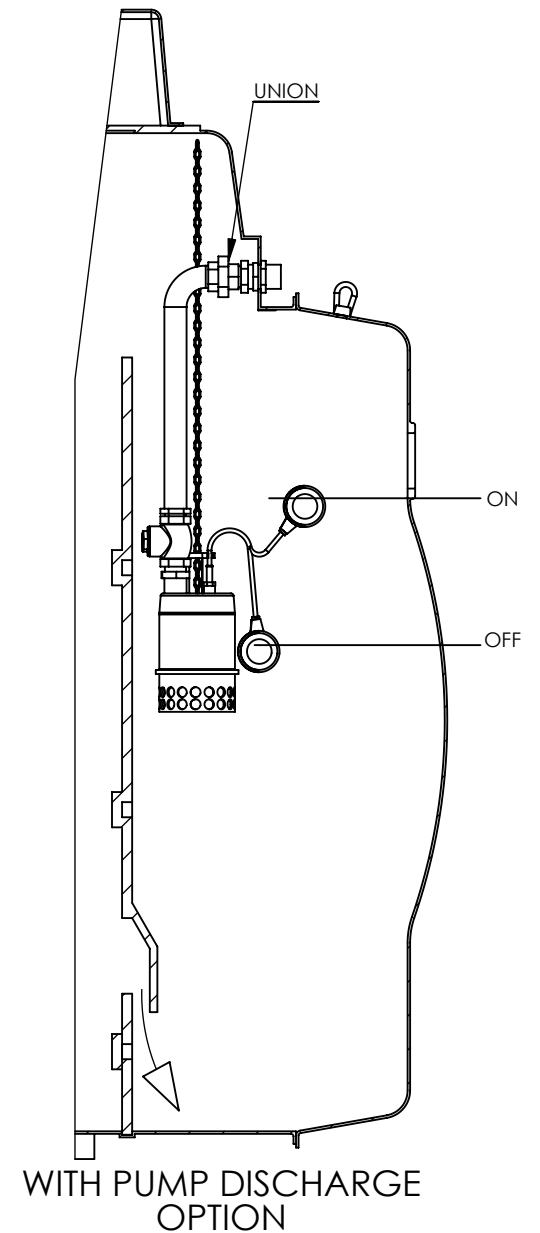

Croom, Enmore Road, Enmore, Bridgwater, Somerset, TA5 2AN
Tel: 01278 671927 Fax: 01278 671963 E-mail: info@synergy-wtp.co.uk
Web: www.synergy-wtp.co.uk

Drawing Title:
TRICEL P6 & P9 GRAVITY SYSTEM

All dimensions in mm SCALE:1:25

Drawing No: Sheet 1 of 1

TRI-CEL P6/9

Date: 15/07/2010

Drawn by: P Martin